

Loadbreak Apparatus Connectors

200 A 15 kV Class Loadbreak Bushing Insert

500-12

GENERAL

The Cooper Power Systems RTE® Bushing Insert threads into a universal bushing well to provide the same function as an integral loadbreak bushing. Using bushing inserts makes field installation and replacement possible and efficient. Bushing inserts and elbow connectors comprise the essential components of all loadbreak connections.

The RTE Bushing Insert uses a patented "ALL COPPER CURRENT PATH," containing only one current transfer point, within the insert itself. The uncomplicated nature of the current path design delivers superior, reliable performance.

An internal hex broach allows for positive torque controlled installation. Using the optional installation torque tool the bushing insert can be properly tightened into the bushing well without the fear of accidentally breaking the bushing well stud.

Cooper's exclusive latch indicator ring, located on the circumference of the bushing's collar, eliminates the guesswork of loadbreak elbow installation on the bushing insert. The bright yellow ring provides immediate feedback to determine if the elbow is properly installed on the insert. If the yellow ring is completely covered by the loadbreak elbow, it is fully "latched," if the ring is visible, the elbow can be installed correctly before any problems can occur.

The bushing insert meets all the requirements of ANSI/IEEE Standard 386 and is completely interchangeable with mating products that also meet ANSI/IEEE Standard 386. When mated with a comparably rated component, the bushing insert provides a fully shielded and submersible connection for loadbreak operation.

INSTALLATION

No special tools are necessary. The insert can be installed by hand or with the assistance of a torque tool. Using the hex-broached base (see Figure 2) and the optional Installation Torque Tool, consistent installation can be easily achieved. Refer to Installation Instruction Sheet S500-12-1 for details.



Figure 1. Loadbreak Bushing Insert with latch indicator ring and "All Copper Current Path" for application in transformers, switches and other apparatus.

PRODUCTION TESTS

Tests conducted in accordance with ANSI/IEEE Standard 386:

- ac 60 Hz 1 Minute Withstand —34 kV
- Minimum Corona Voltage Level —11 kV

Tests conducted in accordance with Cooper Power Systems requirements:

- Physical Inspection
- Periodic Dissection
- Periodic Fluoroscopic Analysis

TABLE 1
Voltage Ratings and Characteristics

Description	kV
Standard Voltage Class	15
Maximum Rating Phase-to-phase	14.4
Maximum Rating Phase-to-ground	8.3
ac 60 Hz 1 Minute Withstand	34
dc 15 Minute Withstand	53
BIL and Full Wave Crest	95
Minimum Corona Voltage Level	11

Voltage ratings and characteristics are in accordance with ANSI/IEEE Standard 386.

TABLE 2
Current Ratings and Characteristics

Description	Amperes
Continuous Switching	200 A rms 10 operations at 200 A rms at 14.4 kV
Fault Closure	10,000 A rms symmetrical at 14.4 kV after 10 switching operations for 0.17 s
Short Time	10,000 A rms symmetrical for 0.17 s 3,500 A rms symmetrical for 3.0 s

Current ratings and characteristics are in accordance with ANSI/IEEE Standard 386.

ORDERING INFORMATION

The standard insert kit is packaged in a heavy duty polyethylene bag. Thirty individual kits are packed to a single multi-pak box. Other packaging options are also available. Please contact the factory for the appropriate part numbers. To order the 15 kV Class Loadbreak Bushing Kit, refer to Table 3.

Features and Detailed Description

Quality from
Cooper Industries

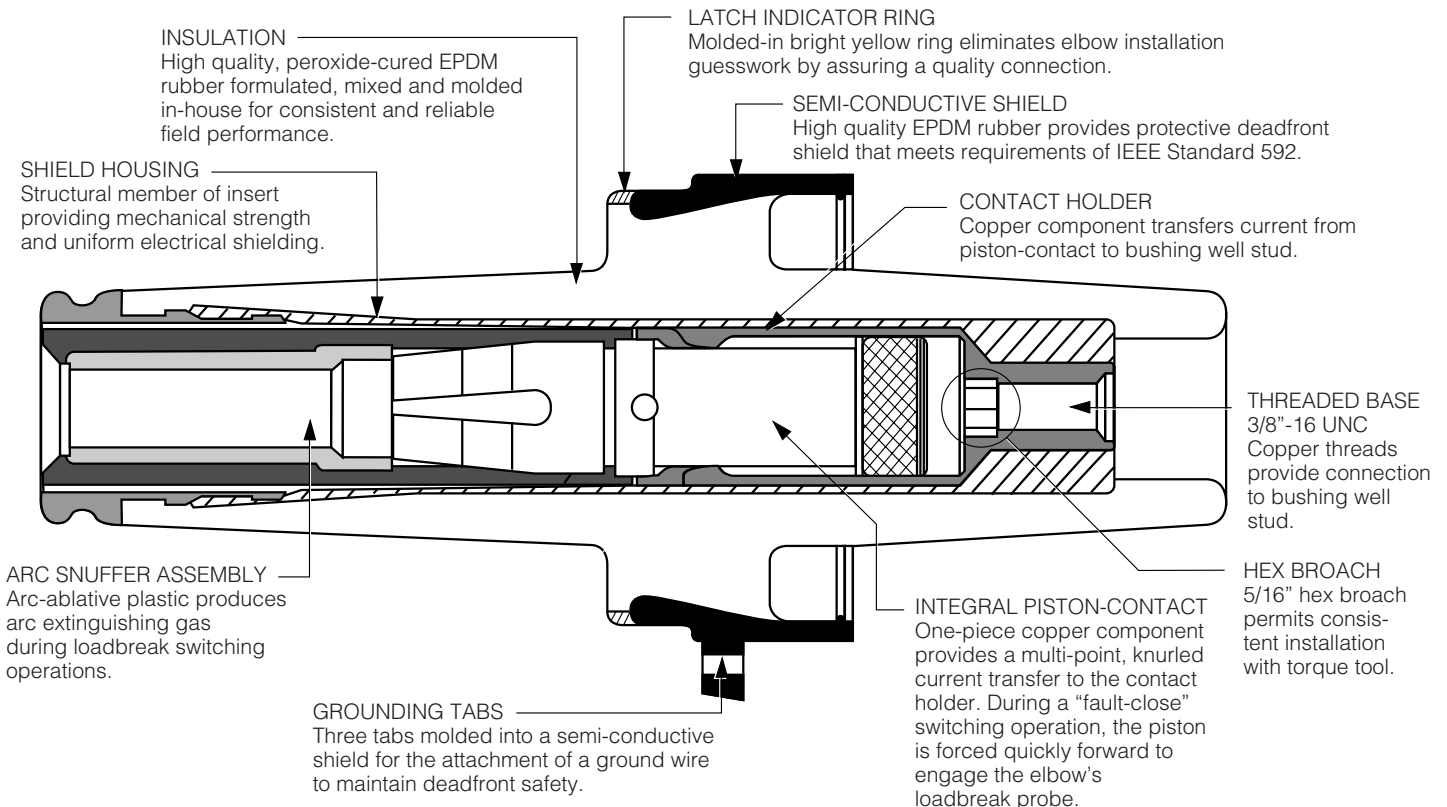

Figure 2.
Bushing Insert cutaway illustrates uncomplicated nature of current path (Patent No. 5,277,605).

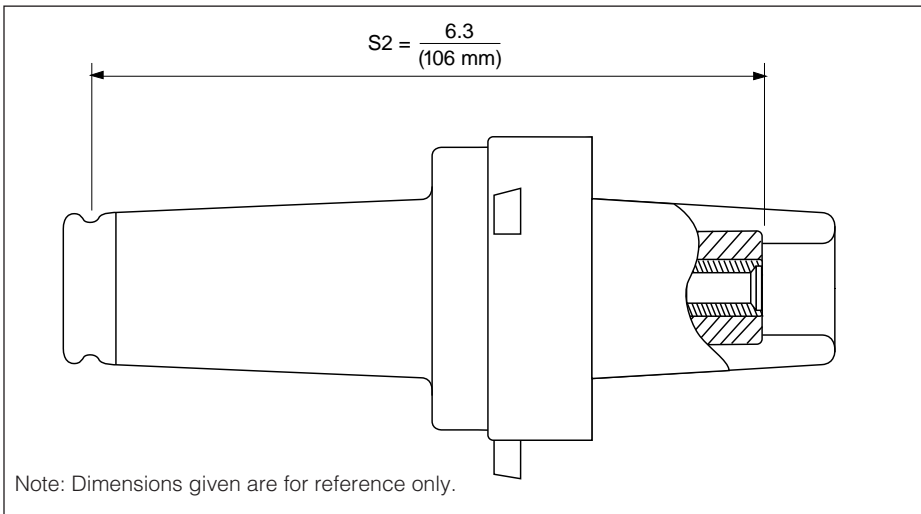

Figure 3.
Bushing Insert profile and stacking dimensions, as referenced in Figure 13 ANSI/IEEE Standard 386.



Figure 4.
Insert installation torque tool.

TABLE 3
Loadbreak Bushing Insert Kit

Description	Catalog Number
Loadbreak Bushing Insert	LBI215
Installation Torque Tool	LBITOOL

Each kit contains:

- Loadbreak Bushing Insert
- Shipping Cap (not for energized operation)
- Silicone Lubricant
- Installation Instruction Sheet



Cooper Power Systems